

ALUMINIUM SOUND PROJECTOR

DO3-51-3003-PA15-V020704

Page 1/1

PA15
Code 3003

DESCRIPTION

- Extruded cylindrical white painted aluminium.
- Dual cones wide band silicon treated speaker.
- Impregnated low insertion loss multi-taps transformer.
- Three models:
- Unidirectional speaker.
- Ideal for music, speech and Emergency messages.
- Suitable either for Indoor or Outdoor use.

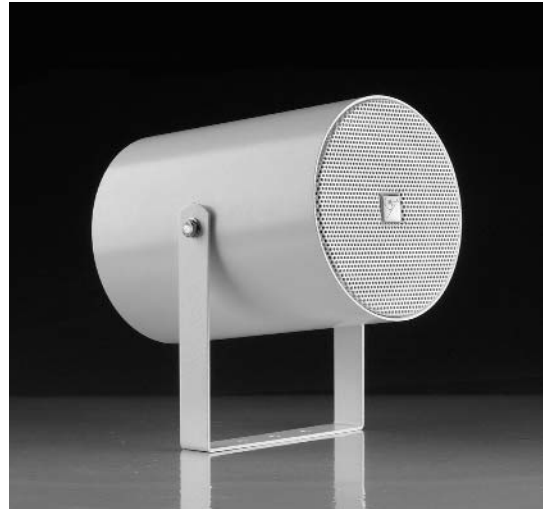

TECHNICAL SPECIFICATIONS

Nominal Power (100V)	Watts	15
Maximum Power	Watts	30
Frequency response	Hertz	90-18000
SPL (max) 1W@1m	dB	92-(104)
Connection	Terminal	
Jumper power Selector (100V)	Watts	15/8/4/2
Impédances	Ohms	0,6/1,25/2,5/5K
Pack dimensions : WxHxD	mm	160x250x155
Pack Weight	Kg	2,5

WIRING

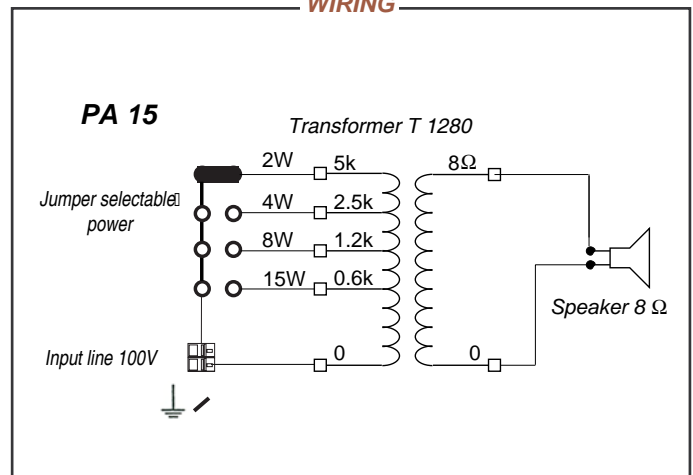

DIMENSIONS

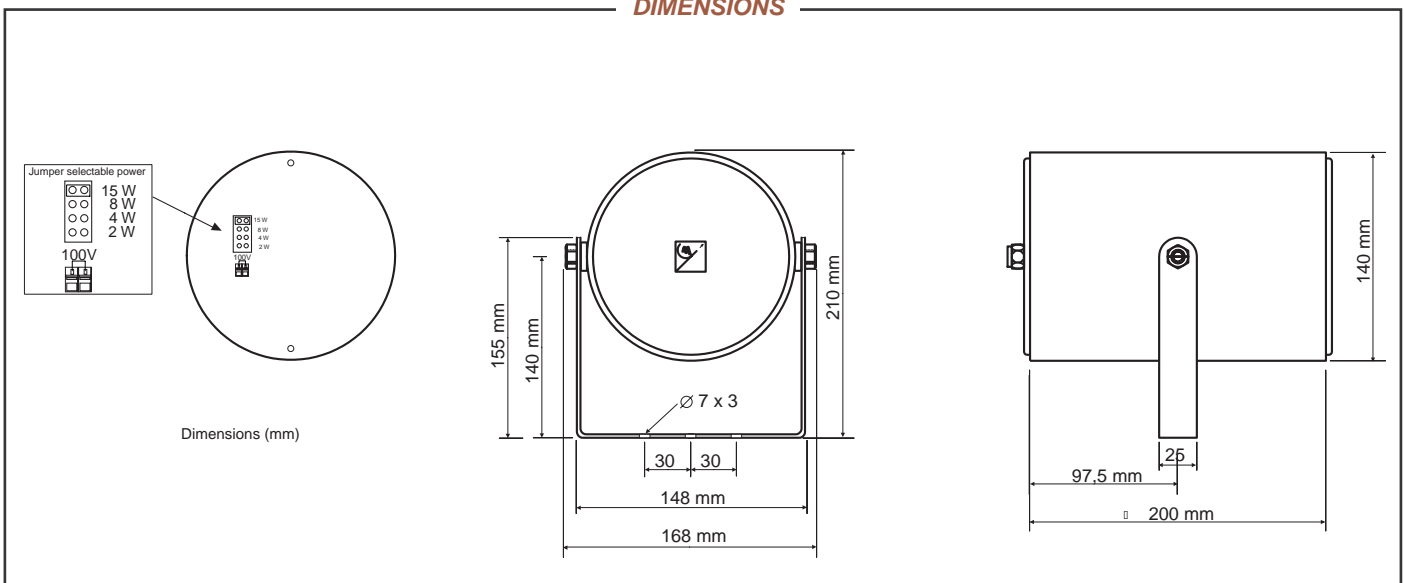

MERLAUD

9 rue de La Briqueterie - P.A.E. des FAUVETTES - 95330 DOMONT (FRANCE)
Tel. 01 39 91 77 78 - Fax 01 39 91 90 66 - www.merlaud.com - merlaud@merlaud.com

SPECIFICATIONS SUBJECT TO MODIFICATIONS