

# ENCEINTE SPHERIQUE

DO3-51-3084-SH215T-V171202

Page 1/1

SH215T

Code 3084

## DESCRIPTION

- Sobres et esthétiques
- Enceintes closes ABS de forme sphérique
- Haut parleur bi-cône large bande à membrane siliconée
- Transformateur imprégné
- Suspension par anneau
- Idéales pour une utilisation en intérieur.



## SPECIFICATIONS TECHNIQUES

Puissance Nominal (100V)	Watts	15
Puissance Maximum	Watts	30
Domaine utile des Fréquences	Hertz	90-18000
Pression Acoustique 1w (Totale)/1m dB		92-(104)
Connexion		Cable 4 fils
Sélecteur de puissance	Watts	15/8/4
Impédances	Ohms	0,7/1,25/2,5K
Dimensions emballage: LxHxP	mm	210x210x210
Poids avec emballage	Kg	1,6

## SCHEMA

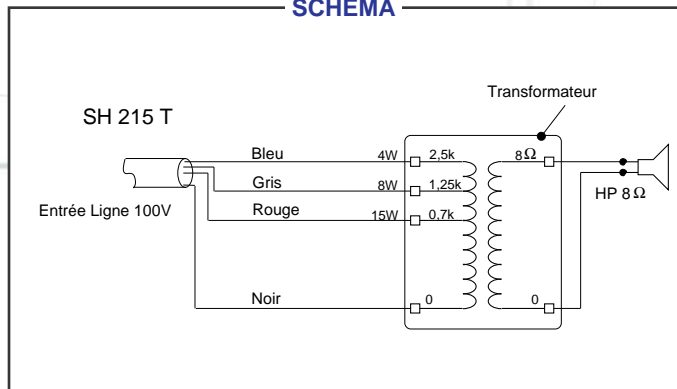

## DIMENSIONS

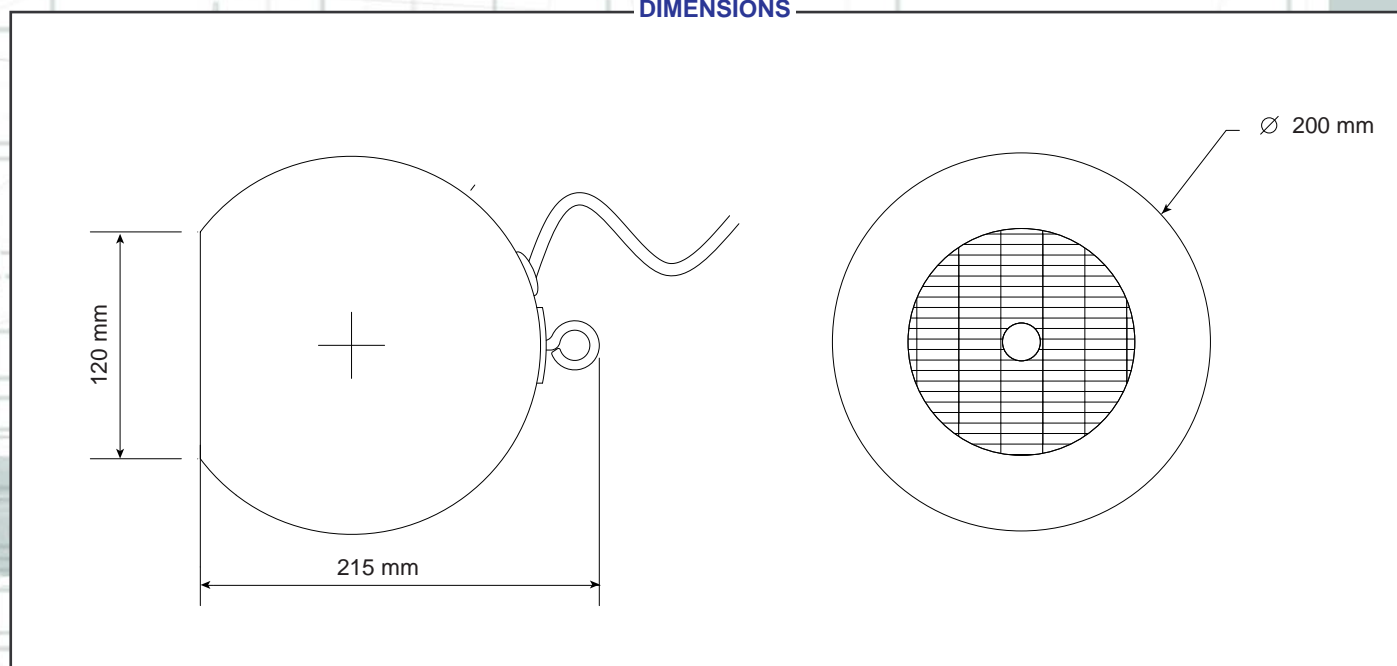

SPECIFICATIONS SUBJECT TO MODIFICATIONS

DOCUMENT NON CONTRACTUEL

# SPHERICAL

DO3-51-3084-SH215T-V171202

Page 1/1

SH215T

Code 3084

## DESCRIPTION

- Aesthetic with high performance spherical speaker.
- Moulded white colour ABS. Other colours on request.
- Dual cones wide band silicon treated speaker.
- Impregnated low insertion loss multi-taps transformer.
- Hanging
- Suitable for high ceiling areas and Indoor use.



## TECHNICAL SPECIFICATIONS

Nominal Power (100V)	Watts	15
Maximum Power	Watts	30
Frequency response	Hertz	90-18000
SPL (max) 1W@1m	dB	92-(104)
Connection	4 Wires cable	
Power Selector (100V)	Watts	15/8/4
Impédances	Ohms	0,7/1,25/2,5K
Pack dimensions : WxHxD	mm	210x210x210
Pack Weight	Kg	1,6

## WIRING

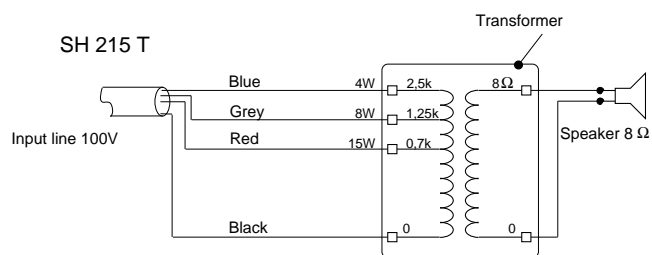

## DIMENSIONS

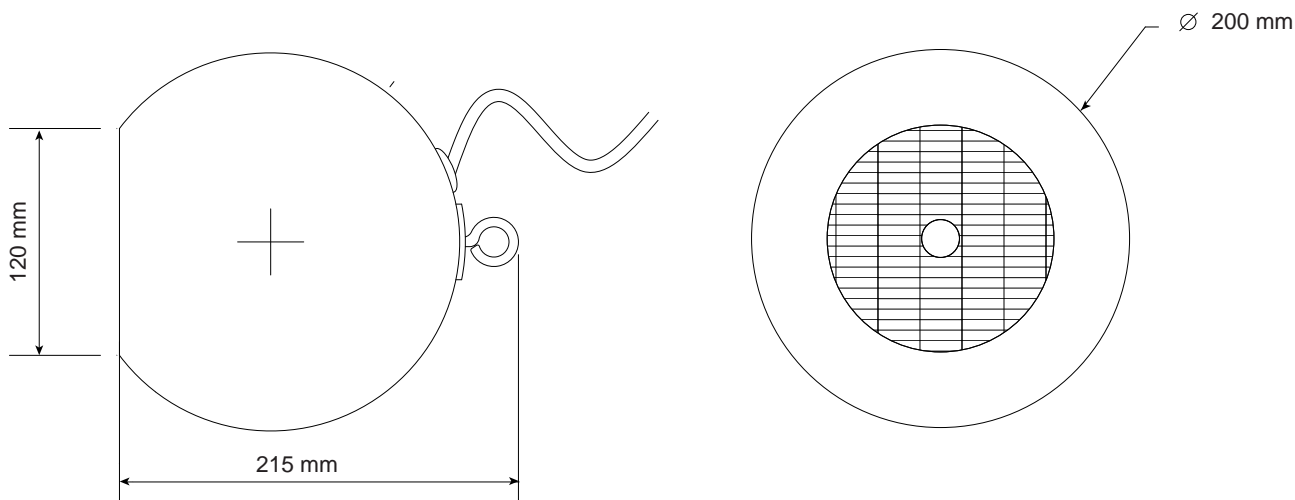

SPECIFICATI...

DOCUMENT NON CONTRACTUEL

Système de management certifié



**MERLAUD**

9 rue de La Briquetterie - P.A.E. des FAUVETTES - 95330 DOMONT (FRANCE)

Tel. 01 39 91 77 78 - Fax 01 39 91 90 66 - [www.merlaud.com](http://www.merlaud.com) - [merlaud@merlaud.com](mailto:merlaud@merlaud.com)

D03-51 FT NT V040412